

# CUSTOM MADE VALVE

ROBINETTERIE FORGÉE À SOUFFLET  
BELLOWS SEALED FORGED VALVE

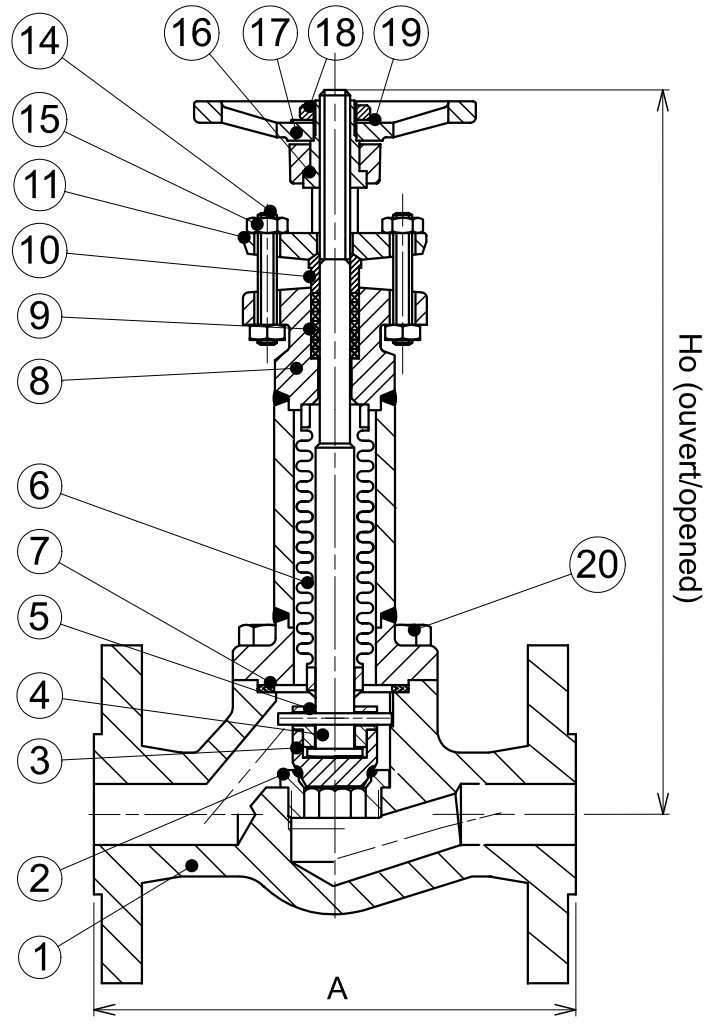
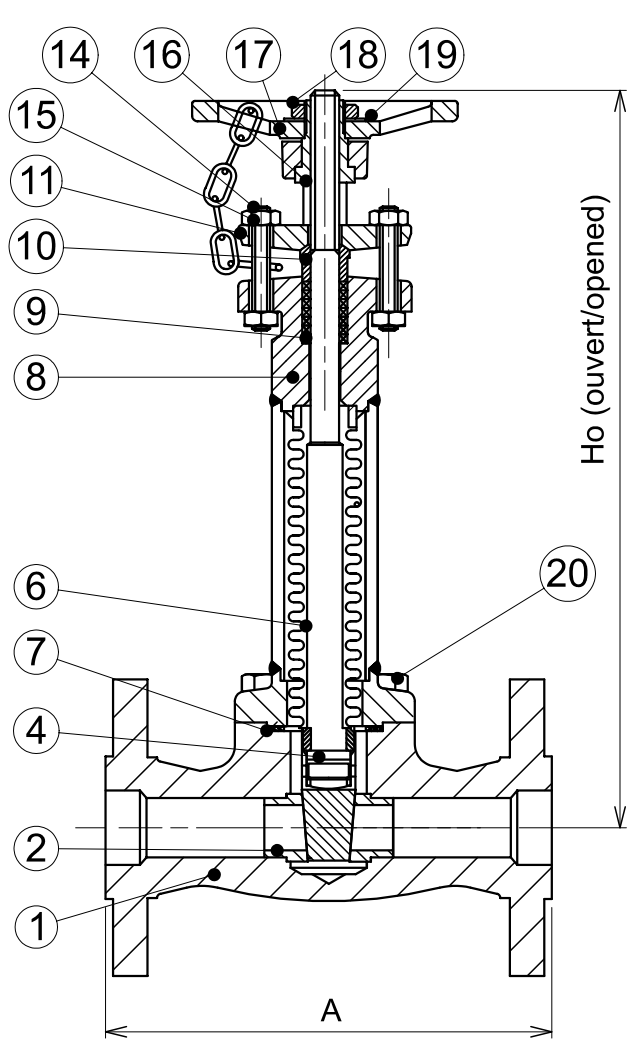

SERIE / CLASS

150 - 300 - 600 - 900 - 1500 - 2500

PN

10 - 16 - 25 - 40 - 65 - 100 - 160

ENDS

BW - NPT - SW - HUB - BRIDE / FLANGE  
FF - RF - RTJ

## COMPONENT PARTS

Rep.	DESIGNATION
1	CORPS/BODY
2	SIEGE/SEAT
3	CLAPET/DISC
4	TIGE/STEM
5	ECROU DE CLAPET/DISC NUT
6	SOUFFLET/BELLOWS SEAL
7	JOINT DE CHAPEAU/BONNET GASKET
8	CHAPEAU/BONNET
9	GARNITURE D'ETANCHEITE/PACKING
10	FOULOIR/GLAND
11	BRIDE DE FOULOIR/GLAND FLANGE
12	OBTURATEUR/WEDGE
14	TIRANT/GLAND FLANGE STUD
15	ECROU DE TIRANT/GLAND FLANGE NUT
16	DOUILLE/BUSHING
17	VOLANT/HANDWHEEL
18	ECROU DE VOLANT/HANDWHEEL NUT
19	PLAQUE D'IDENTIFICATION/NAME PLATE
20	VIS DE CHAPEAU/BONNET SCREW

Encombrement A suivant NFE 29-305  
Face to face acc. ANSI B16.10  
Matériel conforme à NF M87.412-BS5352  
Material in acc. with BS 5352 - NF M87.412